



LEVEL & LEAK DETECTION

LEVEL TRANSMITTERS LD31, LD32 SERIES DELTASPAN

DESCRIPTION

The Flowline DeltaSpan LD31 and LD32 Series submersible pressure level transmitters provide continuous level measurement up to 46 ft (14m) of water column with a 4-20 mA signal output. Select the **LD31 Series** liquid level sensor for relatively clean water, light weight oil or diluted chemical. Application examples include water wells and ponds. Select the **LD32 Series** liquid level sensor for dirty, foaming or slurry type liquids. Application examples include municipal sewer or storm pump lift stations.

FEATURES

- Corrosion resistant 316 SS body with polyurethane or ETFE cable
- Strong cable design with maintenance free breather tube and vent filter
- Automatic temperature compensation for accurate measurement
- Rugged clog and damage resistant diaphragm design (LD32 Series only)

NEW!



LD31



LD32



SPECIFICATIONS

Supply Voltage	13 to 30 VDC	Measurement Range	up to 46 ft (14m)
Signal Output		Cable Length	
LD31	4-20 mA, two-wire @ 900Ω	SX01 & SX11	40 ft (12.2m)
LD32	4-20 mA, two-wire @ 850Ω	SX21 & SX31	60 ft (18.3m)
Maximum Output Impedance	mA	Cable Type	Polyurethane cable jacket and ETFE cable jacket
LD31	900Ω @ 30 VDC	Weight	
LD32	850Ω @ 30 VDC	LD31	2.2 lb (1.0 kg)
Accuracy	± 0.25% of full scale	LD32	4.3 lb (2.0 kg)
Proof Pressure	2 x full scale	Approvals	CE, RoHS
Process Temperature		Warranty	1 year
LD31	0° to 150°F (-18° to 66°C)		
LD32	0° to 180°F (-18° to 82°C)		

DIMENSIONS

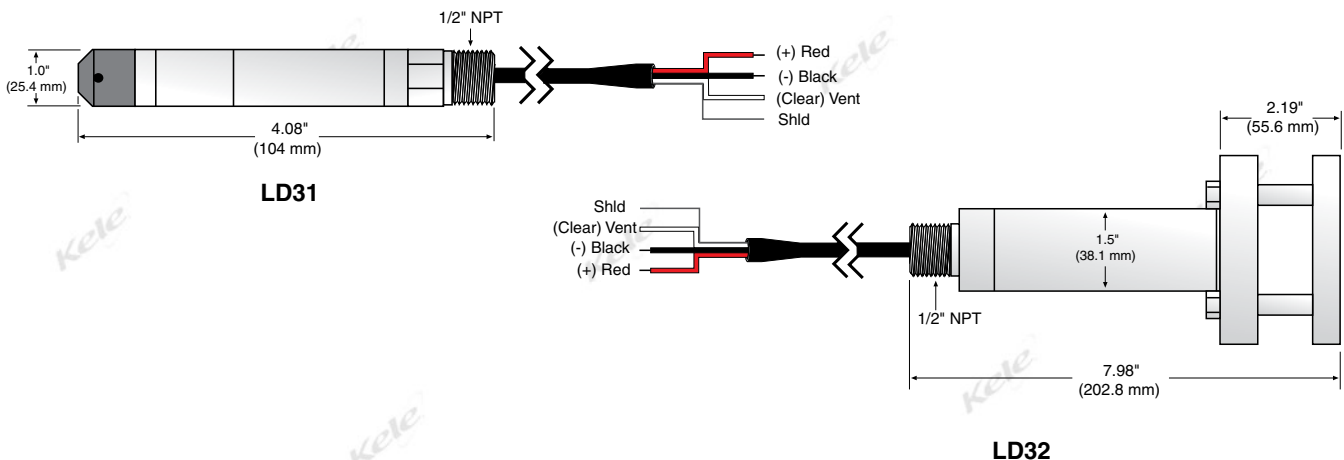

10

LEVEL & LEAK DETECTION

NEW!

LEVEL & LEAK DETECTION

LEVEL TRANSMITTERS LD31, LD32 SERIES DELTASPAN



ORDERING INFORMATION

MODEL	DESCRIPTION
LD31	Submersible pressure level transmitter, clean liquid applications
LD32	Submersible pressure level transmitter, dirty liquid applications
CABLE JACKET	
S1	Polyurethane (standard)
S2	ETFE (used for aggressive liquids)
RANGE ft (m) and CABLE LENGTH	
01	0-11' (0-3.4), 40 ft (12.2m) cable
11	0-23' (0-7), 40 ft (12.2m) cable
21	0-34' (0-10.4), 60 ft (18.3m) cable
31	0-46' (0-14), 60 ft (18.3m) cable

LD31

S111

Example: LD31-S111 Model pressure transmitter with polyurethane cable jacket and 0-23 ft range

DCPA-1.2
DCP-1.5-W

RELATED PRODUCTS

Power supply, 120 VAC IN to 24 VAC/24 VDC OUT
Power supply, 24 VAC IN to 24 VDC OUT

10

LEVEL & LEAK DETECTION